

**ROLLON**<sup>®</sup>

Linear Evolution

X-Rail



## Product explanation



### > X-Rail: Corrosion resistant or zinc-plated steel linear bearings



Fig. 1

X-Rail is the product family of roller embossed guide rails for applications in which an economical price to performance ratio and high corrosion resistance are required.

X-Rail includes two sets of products: a rail with shaped raceways (0 degrees of axial play) and a rail with flat raceways (1 degree of axial play).

All products are available in stainless steel or zinc-plated steel. There are three different sizes of guide rails, and the sliders for the guide rails are available in different versions.

#### The most important characteristics:

- Corrosion resistant, FDA/USDA compliant materials
- Compensates for deviations in mounting structure parallelism
- Not sensitive to dirt due to internal tracks
- Wide temperature range of application
- Easy adjustment of sliders on the guide rails

#### Preferred areas of application of the X-Rail product family:

- Construction and machine technology (e.g., safety doors, washing bay accessories)
- Medical technology (e.g., hospital accessories, medical equipment)
- Transport (e.g., rail transport, naval, automotive industry)
- Food and beverage industry (e.g., packaging, food processing)
- Building technology
- Energy technology (e.g., industrial furnaces, boilers)

### Fixed bearings (T-rails)

Fixed bearing rails are used for the main load bearing in radial and axial forces.



Fig. 2

### Compensating bearings (U-rails)

Compensating bearing rails are used for load bearing of radial forces and, in combination with fixed bearing rails as support bearings for occurring moment loads.



Fig. 3

### System (T+U-System)

A T and U-rail used together offers compensation for deviations in parallelism and tolerances in the mounting structure.



Fig. 4

### Rollers

Concentric and eccentric radial ball bearings made of stainless or roller bearing steel are available for each slider. Roller sealing is dependent on the material: 2RS rubber seals or 2Z steel shields. All rollers are lubricated for life.



Fig. 5

## Technical data

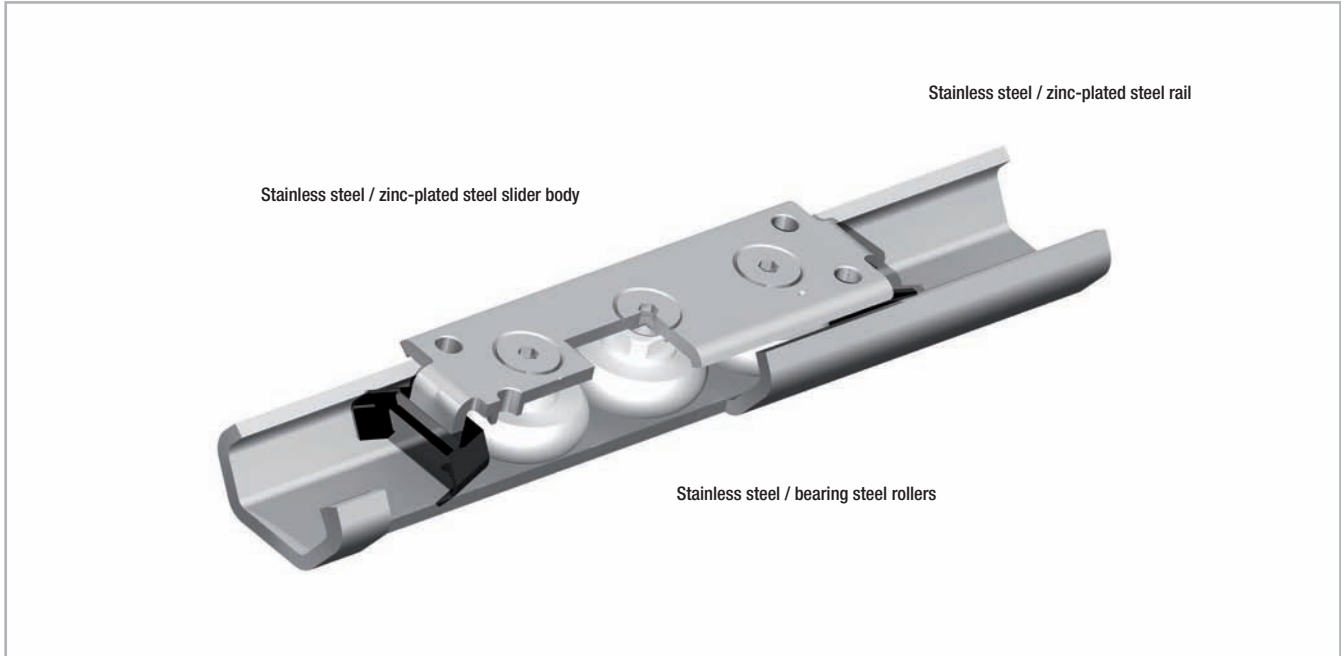

Fig. 6

### Performance characteristics:

- Available sizes: 20, 30, 45
- Max. slider operating speeds in the linear bearing rails: 1.5 m/s (59 in/s) (depending on application)
- Max. acceleration: 2 m/s<sup>2</sup> (78 in/s<sup>2</sup>) (depending on application)
- Max. traverse: 3,060 mm (120 in) (depending on size)
- Max. radial load capacity: 1,740 N (per slider)
- Temperature range for stainless steel rails: -30 °C to +100 °C (-22 °F to +212 °F), or steel rails: -30 °C to +120 °C (-22 °F to +248 °F)
- Available rail lengths from 160 mm to 3,120 mm (6.3 in to 122 in) in 80-mm increments (3.15 in)
- Rollers lubricated for life
- Roller seal/shield:  
CEX... Sliders => 2RS (splashproof seal),  
CES... Sliders => 2Z (dust cover seal)
- Material: Stainless steel rails TEX... / UEX... 1.4404 (AISI 316L),  
Steel rails TES... / UES... zinc-plated ISO 2081
- Material rollers: Stainless steel 1.4110 (AISI 440)

### Remarks:

- The sliders are equipped with rollers that are in alternating contact with both sides of the raceway. Markings on the body around the outer roller pins indicate the correct arrangement of the rollers to the external load.  
Important note: Both outside rollers carry the radial load.
- With a simple adjustment of the eccentric roller, clearance or the desired preload can be set on the rail and slider.
- Sliders of Version 1 (with compact body) come standard with plastic wipers for cleaning the raceways.
- Wipers for sliders of Versions 2 and 3 on request (see pg. XR-6 and XR-7).
- We do not recommend combining (stringing together) the rails.
- Recommended fixing screws according to ISO 7380 with low head height or TORX® screws on request.

## > Load capacities

### Fixed bearings

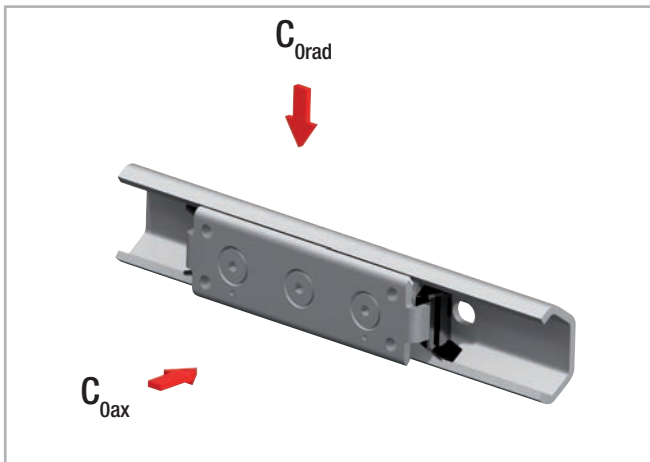

Fig. 7

Configuration	$C_{Orad}$ [N]	$C_{Oax}$ [N]
TEX-20 – CEX20	300	170
TEX-30 – CEX30	800	400
TEX-45 – CEX45	1600	860
TES-20 – CES20	326	185
TES-30 – CES30	870	435
TES-45 – CES45	1740	935

Tab. 1

Resulting moment loads must be absorbed through the use of two sliders

### Compensating bearings

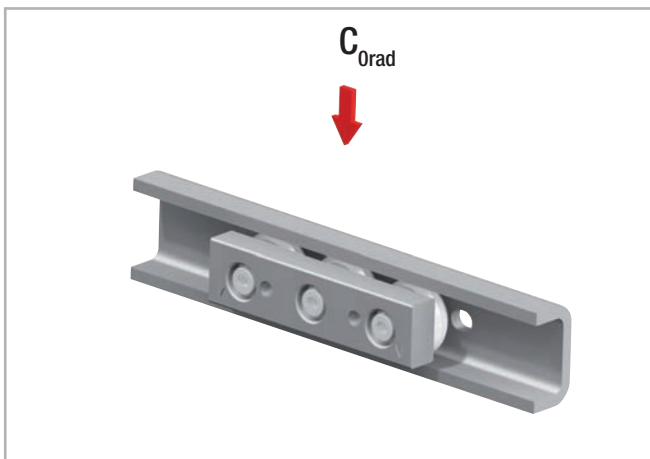

Fig. 8

Configuration	$C_{Orad}$ [N]
UEX-20 – CEXU20	300
UEX-30 – CEXU30	800
UEX-45 – CEXU45	1600
UES-20 – CESU20	326
UES-30 – CESU30	870
UES-45 – CESU45	1740

Tab. 2

# Product dimensions

## > Fixed rails

Rail (TEX = stainless steel / TES = zinc-plated steel)

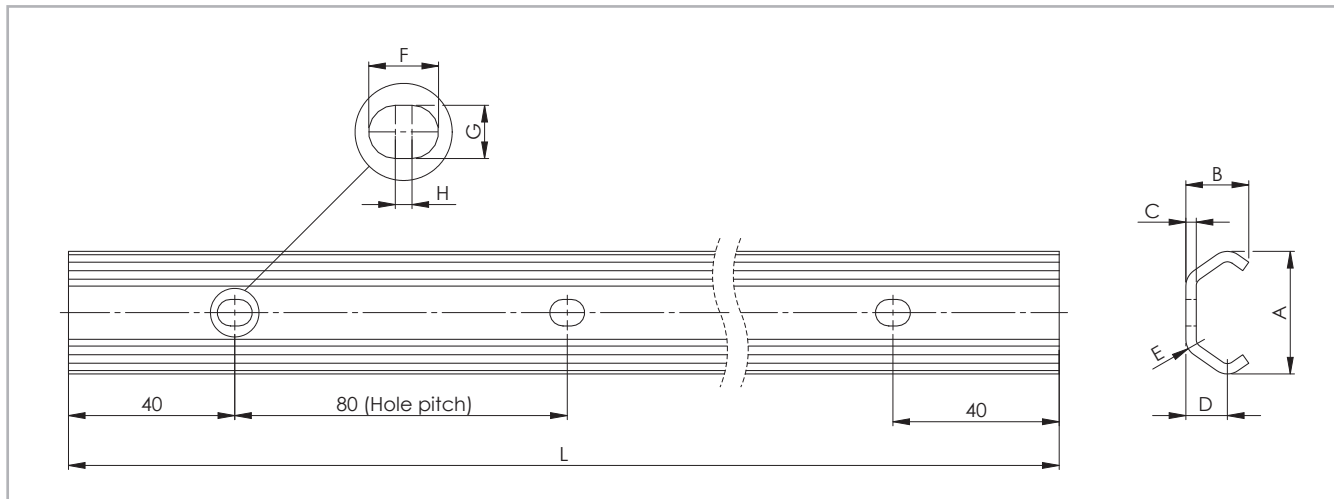

Fig. 9

Rail type	Size	A [mm]	B [mm]	C [mm]	D [mm]	E [mm]	F [mm]	G [mm]	H [mm]	Holes for screws	Weight [kg/m]
TEX	20	19.2	10	2	7	3	7	5	2	M4	0.47
	30	29.5	15	2.5	10	4.5	8.4	6.4	2	M5	0.90
TES	45	46.4	24	4	15.5	6.5	11	9	2	M8	2.29

Tab. 3

Rail type	Standard length L [mm]
TEX	160 - 240 - 320 - 400 - 480 - 560 - 640 - 720 - 800 - 880 - 960 - <b>1040</b> - 1120 - 1200 - 1280 - 1360 - 1440 - 1520 - 1600 - 1680
TES	- 1760 - 1840 - 1920 - 2000 - <b>2080</b> - 2160 - 2240 - 2320 - 2400 - 2480 - 2560 - 2640 - 2720 - 2800 - 2880 - 2960 - 3040 - <b>3120</b>

Tab. 4

Please specify hole pattern separately  
 Special lengths or pitches available upon request, please contact the sales department  
 The highlighted rail lengths are available from stock

**Slider (CEX = stainless steel / CES = zinc-plated steel)**

Version 1 (with compact body for fixed rails)

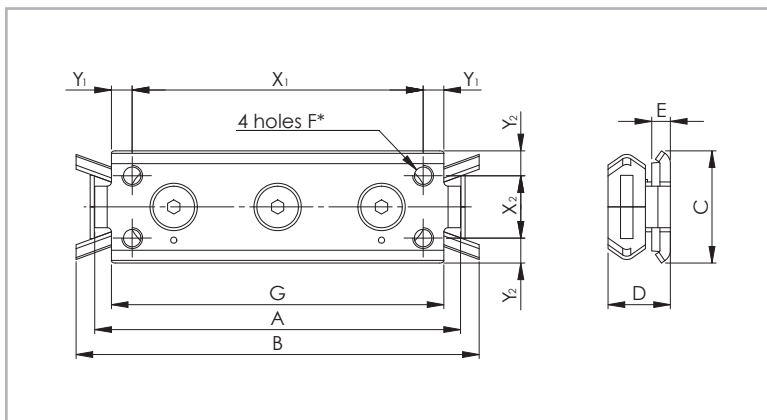

\* For size 20: 2 M5 holes on the centreline with distance X<sub>1</sub>

Fig. 10

Slider type	Size	A [mm]	B [mm]	C [mm]	D [mm]	E [mm]	F	G [mm]	X <sub>1</sub> [mm]	Y <sub>1</sub> [mm]	X <sub>2</sub> [mm]	Y <sub>2</sub> [mm]	Weight [kg]
CEX20-80 CES20-80	20	80	90	18	11.5	5.5	M5	71	60	5,5	-	9	0.05
CEX30-88 CES30-88	30	88	97	27	15	4.5	M5	80	70	5	15	6	0.11
CEX45-150 CES45-150	45	150	160	40	22	4	M6	135	120	7.5	23	8.5	0.40

Tab. 5

Version 2 (with solid body for fixed rails)

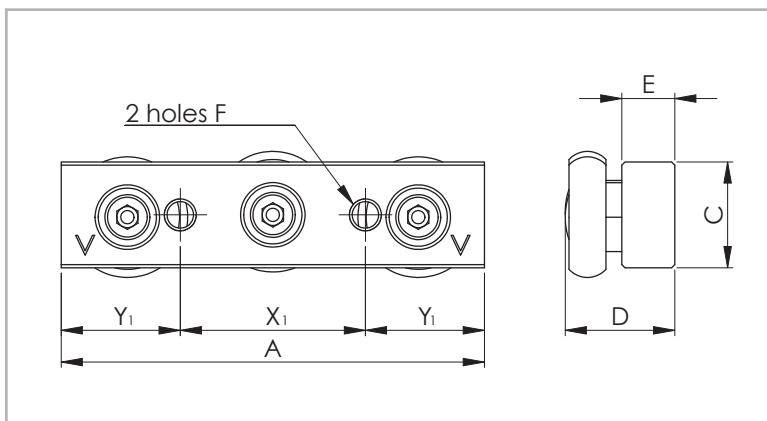

Slider version with wipers on request

Fig. 11

Slider type	Size	A [mm]	C [mm]	D [mm]	E [mm]	F	X <sub>1</sub> [mm]	Y <sub>1</sub> [mm]	Weight [kg]
CEX20-60 CES20-60	20	60	10	13	6	M5	20	20	0.04
CEX30-80 CES30-80	30	80	20	20.7	10	M6	35	22.5	0.17
CEX45-120 CES45-120	45	120	25	28.9	12	M8	55	32.5	0.47

Tab. 6

> Compensating rails

Rail (UEX = stainless steel / UES = zinc-plated steel)

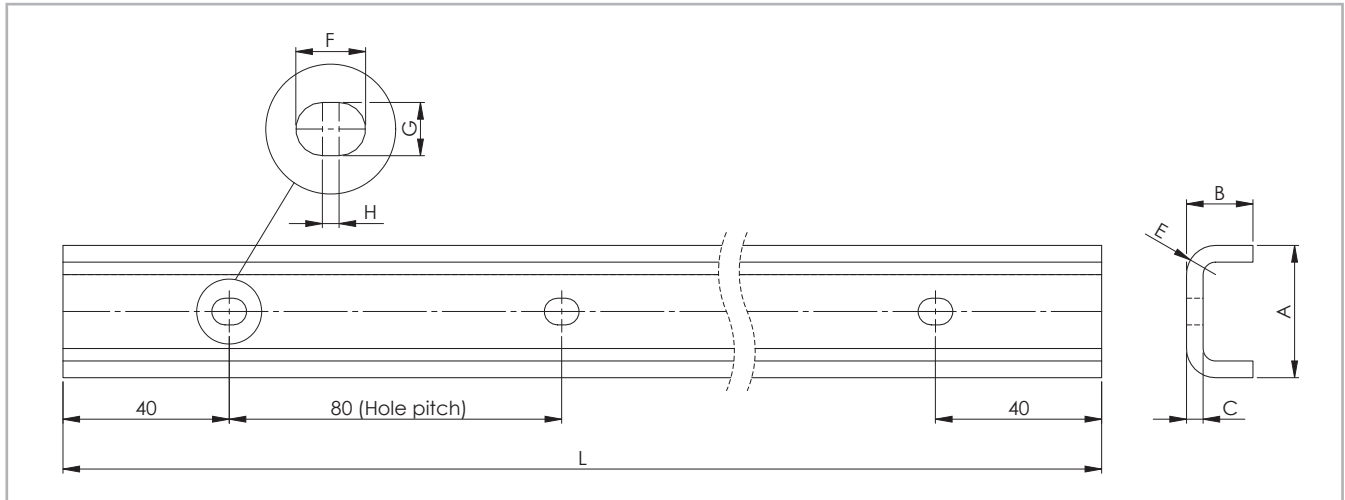

Fig. 12

Rail type	Size	A [mm]	B [mm]	C [mm]	E [mm]	F [mm]	G [mm]	H [mm]	Holes for screws	Weight [kg/m]
UEX	20	20.5	11	3	5.5	7	5	2	M4	0.77
	30	31.8	16	4	7	8.4	6.4	2	M5	1.39
UES	45	44.8	24.5	4.5	9.5	11	9	2	M8	2.79

Tab. 7

Rail type	Standard length L [mm]
UEX	160 - 240 - 320 - 400 - 480 - 560 - 640 - 720 - 800 - 880 - 960 - <b>1040</b> - 1120 - 1200 - 1280 - 1360 - 1440 - 1520 - 1600 - 1680
UES	- 1760 - 1840 - 1920 - 2000 - <b>2080</b> - 2160 - 2240 - 2320 - 2400 - 2480 - 2560 - 2640 - 2720 - 2800 - 2880 - 2960 - 3040 - <b>3120</b>

Tab. 8

Please specify hole pattern separately  
 Special lengths or pitches available upon request, please contact the sales department  
 The highlighted rail lengths are available from stock



**Slider (CEXU = stainless steel / CESU = zinc-plated steel)**

Version 3 (with solid body for compensating rail)

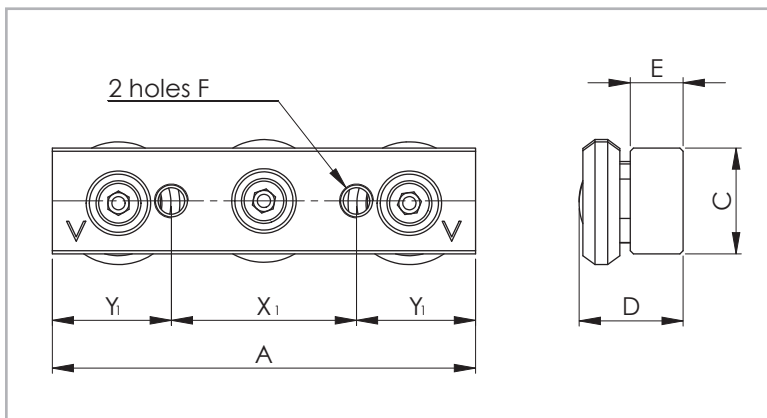

Slider version with wipers on request

Fig. 13

Slider type	Size	A [mm]	C [mm]	D [mm]	E [mm]	F [mm]	X <sub>1</sub> [mm]	Y <sub>1</sub> [mm]	Weight [kg]
CEXU20-60 CESU20-60	20	60	10	11.85	6	M5	20	20	0.04
CEXU30-80 CESU30-80	30	80	20	19.9	10	M6	35	22.5	0.16
CEXU45-120 CESU45-120	45	120	25	26.4	12	M8	55	32.5	0.45

Tab. 9

> Mounted sliders and rails

Fixed rails

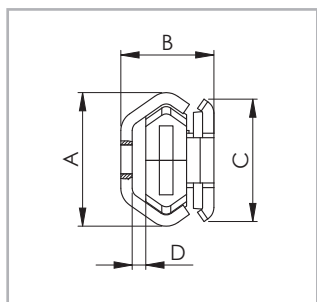

Fig. 14

Version 1  
(Slider with compact body)

Configuration	A [mm]	B [mm]	C [mm]	D [mm]
TEX-20 – CEX20-80 TES-20 – CES20-80	19.2	16	18	2.5
TEX-30 – CEX30-88 TES-30 – CES30-88	29.5	20.5	27	3.5
TEX-45 – CEX45-150 TES-45 – CES45-150	46.4	31	40	5

Tab. 10

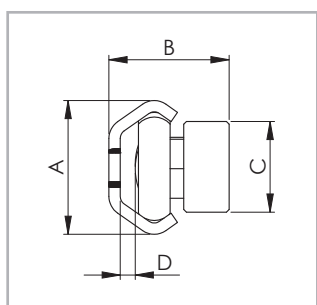

Fig. 15

Version 2  
(Slider with solid body)

Configuration	A [mm]	B [mm]	C [mm]	D [mm]
TEX-20 – CEX20-60 TES-20 – CES20-60	19.2	17.8	10	2.6
TEX-30 – CEX30-80 TES-30 – CES30-80	29.5	26.5	20	3.3
TEX-45 – CEX45-120 TES-45 – CES45-120	46.4	38	25	5.1

Tab. 11

Compensating rails

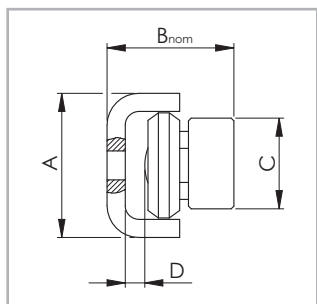

Fig. 16

Version 3  
(Slider with solid body)

Configuration	A [mm]	B <sub>nom</sub> [mm]	C [mm]	D [mm]
UEX-20 – CEXU20-60 UES-20 – CESU20-60	20.5	18.25 ± 0.6	10	3.4
UEX-30 – CEXU30-80 UES-30 – CESU30-80	31.8	27.95 ± 1.0	20	4.05
UEX-45 – CEXU45-120 UES-45 – CESU45-120	44.8	37.25 ± 1.75	25	6.35

Tab. 12

# Accessories

## > Rollers

### Version 1

(Slider with compact body for fixed rails)

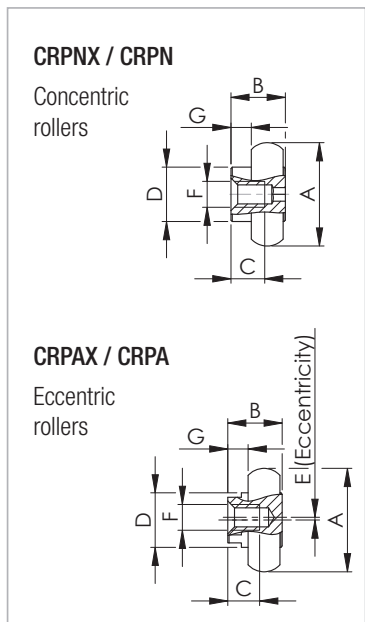

Fig. 17

Roller type	for slider	A [mm]	B [mm]	C [mm]	D [mm]	E [mm]	F	G [mm]	Weight [kg]
CRPNX20-2RS	CEX20-80	14	8.5	6	8	-	M4	4.0	0.006
CRPN20-2Z	CES20-80								
CRPAX20-2RS	CEX20-80					0.5			
CRPA20-2Z	CES20-80								
CRPNX30-2RS	CEX30-88	22.8	12	7	12	-	M5	4.5	0.02
CRPN30-2Z	CES30-88								
CRPAX30-2RS	CEX30-88					0.6			
CRPA30-2Z	CES30-88								
CRPNX45-2RS	CEX45-150	35.6	18	12	16	-	M6	6.0	0.068
CRPN45-2Z	CES45-150								
CRPAX45-2RS	CEX45-150					0.8			
CRPA45-2Z	CES45-150								

Load rate per roller: radial 50 %, axial 33 % of the given slider load rate  
2RS (splashproof seal for CEX slider), 2Z (dust cover seal for CES slider)

Tab. 13

### Version 2

(Slider with solid body for fixed rails)

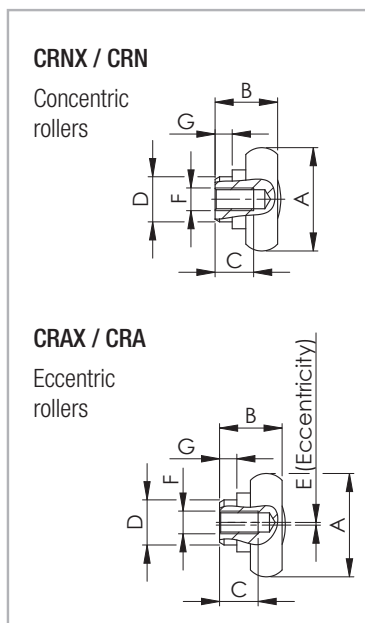

Fig. 18

Roller type	for slider	A [mm]	B [mm]	C [mm]	D [mm]	E [mm]	F	G [mm]	Weight [kg]
CRNX20-2RS	CEX20-60	14	8.7	6	6	-	M4	1.8	0.006
CRN20-2Z	CES20-60								
CRAX20-2RS	CEX20-60					0.5			
CRA20-2Z	CES20-60								
CRNX30-2RS	CEX30-80	22.8	14	9	10	-	M5	3.8	0.022
CRN30-2Z	CES30-80								
CRAX30-2RS	CEX30-80					0.6			
CRA30-2Z	CES30-80								
CRNX45-2RS	CEX45-120	35.6	20.5	14.5	12	-	M6	4.5	0.07
CRN45-2Z	CES45-120								
CRAX45-2RS	CEX45-120					0.8			
CRA45-2Z	CES45-120								

Load rate per roller: radial 50 %, axial 33 % of the given slider load rate  
2RS (splashproof seal for CEX slider), 2Z (dust cover seal for CES slider)

Tab. 14

Version 3

(Slider with solid body for compensating rails)

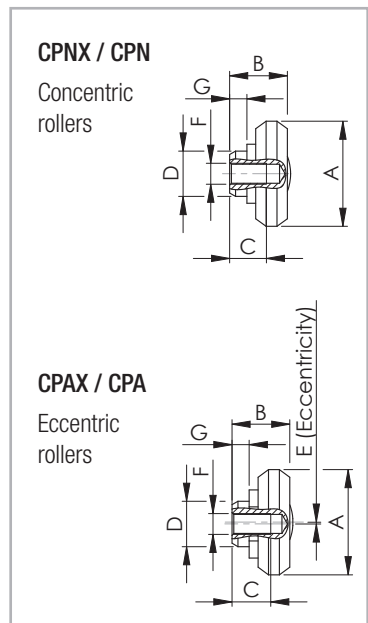

Fig. 19

Roller type	for slider	A [mm]	B [mm]	C [mm]	D [mm]	E [mm]	F	G [mm]	Weight [kg]
CPNX20-2RS	CEXU20-60	14	7.35	5.5	6	-	M4	1.8	0.004
CPN20-2Z	CESU20-60								
CPAX20-2RS	CEXU20-60					0.4			
CPA20-2Z	CESU20-60								
CPNX30-2RS	CEXU30-80	23.2	13	7	10	-	M5	3.8	0.018
CPN30-2Z	CESU30-80								
CPAX30-2RS	CEXU30-80					0.6			
CPA30-2Z	CESU30-80								
CPNX45-2RS	CEXU45-120	35	18	12	12	-	M6	4.5	0.06
CPN45-2Z	CESU45-120								
CPAX45-2RS	CEXU45-120					0.8			
CPA45-2Z	CESU45-120								

Load rate per roller: radial 50 % of given slider load rate  
 2RS (splashproof seal for CEX slider), 2Z (dust cover seal for CES slider)

Tab. 15

> Fixing screws

We recommend fixing screws according to ISO 7380 with low head height or TORX® screws (see fig. 20) on request.

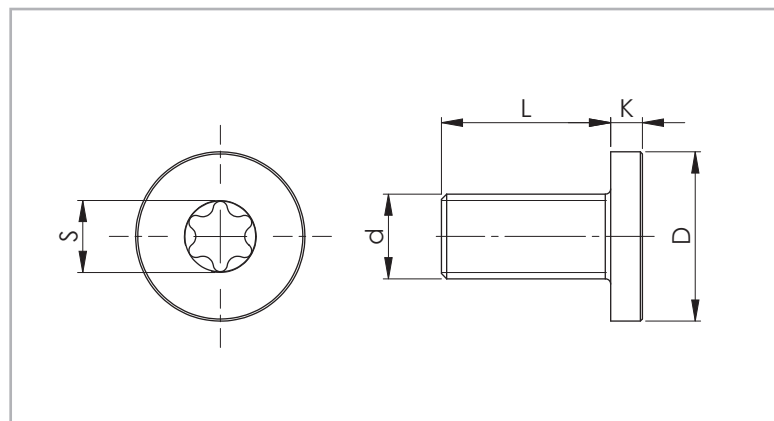

Fig. 20

Rail size	Screw type	d	D [mm]	L [mm]	K [mm]	S	Tightening torque [Nm]
20	M4 x 8	M4 x 0.7	8	8	2	T20	3
30	M5 x 10	M5 x 0.8	10	10	2	T25	9
45	M8 x 16	M8 x 1.25	16	16	3	T40	22

Tab. 16

## Technical instructions



### > Lubrication

All radial ball bearing rollers in the X-Rail series are lubricated for life. It is advisable to lubricate the raceways with specific bearing grease. The interval between lubrication treatments depends mainly on environmental conditions, bearing speed and temperature.

Under normal conditions, it is advisable to lubricate locally after 100 km of use or after six months of service. In case of critical applications, lubrication treatments should be more frequent. Before lubricating, remember to clean the raceway surfaces carefully. We advise using a lithium grease of medium consistency for rolling-element bearings.

Different lubricants are available on request for special applications:

- FDA-approved lubricant for use in the food industry

- specific lubricant for clean rooms
- specific lubricant for the marine technology sector
- specific lubricant for high and low temperatures

For specific information, contact the Rollon technical office.

Under normal conditions, correct lubrication:

- reduces friction
- reduces wear
- reduces stress on contact surfaces due to elastic deformation
- reduces noise during operation
- increases the regularity of the rolling movement

### > T+U-System



Fig. 21

#### Solves axial deviations in parallelism

Mounting two linear bearing rails in a parallel manner is always important but rarely easy. Distortions in axial alignment can drastically reduce the life of the rails. These distortions can bind and overload sliders. Rollon offers an outstanding solution for the alignment of dual track carriages. Using shaped and flat raceways it is possible to avoid axial deviation in parallelism of the mounting surfaces without additional modifications of those surfaces. T+U rails easily address these alignment issues to create an economical parallel rail system.

In a T+U-System, the slider in the T rail carries axial and radial loads and guides the movement of the U, which has lateral freedom.

U rails have flat parallel raceways that allow free lateral movement of the sliders. The maximum freedom a slider in the U rail can offer can be calculated using the values  $S_1$  and  $S_2$  (see pg. XR-14, fig. 22, tab. 19). With nominal value  $B_{nom}$  as the starting point,  $S_1$  indicates the maximum allowed movement into the rail, while  $S_2$  represents the maximum offset towards the outside of the rail.

If the length of the guide rail is known, the maximum allowable angle deviation of the mounting surface (see pg. XR-14, fig. 23) can be obtained. In this case the slide in the U rail has the freedom to travel from the innermost position  $S_1$  to the outermost position  $S_2$ .

Maximum offset

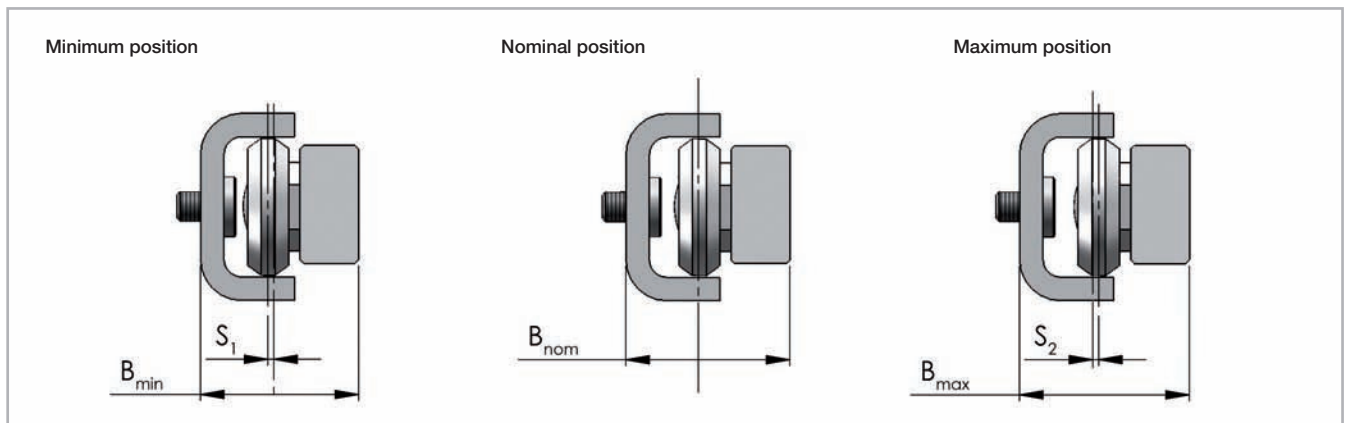

Fig. 22

Slider type (Version 3 with solid body)	S <sub>1</sub> [mm]	S <sub>2</sub> [mm]	B <sub>min</sub> [mm]	B <sub>nom</sub> [mm]	B <sub>max</sub> [mm]
CEXU.../CESU20-60	0.6	0.6	17.65	18.25	18.85
CEXU.../CESU30-80	1	1	26.95	27.95	28.95
CEXU.../CESU45-120	1.75	1.75	35.50	37.25	39

Tab. 17

Guideline for the maximum angle deviation α, achievable with the longest guide rail

$$\alpha = \arctan \frac{S^*}{L}$$

S\* = sum of S<sub>1</sub> and S<sub>2</sub>  
L = length of the rail

Fig. 23

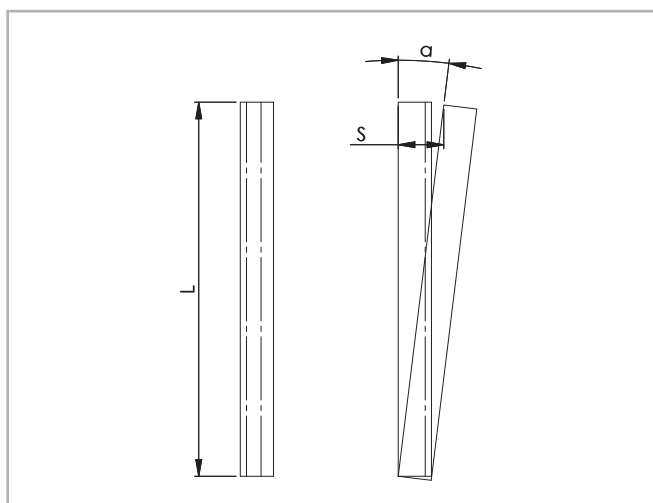

Fig. 24

Size	Rail length [mm]	Offset S* [mm]	Angle α [°]
20	3120	1.2	0.022
30	3120	2	0.037
45	3120	3.5	0.064

Tab. 18

## > Setting preload

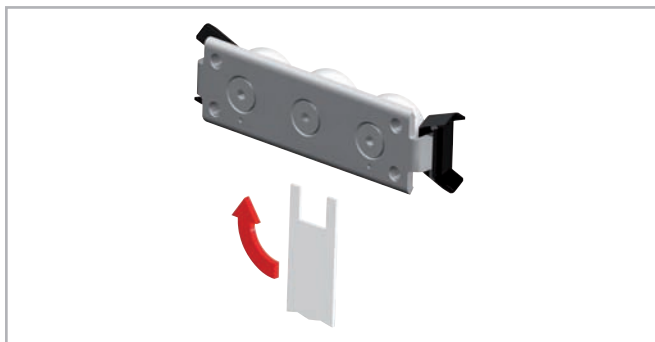

Fig. 25

If the product is delivered with the sliders in the rails, the sliders are already preloaded. If delivered separately, or if the sliders need to be installed in another rail, the sliders must be readjusted. In this case, follow the instructions below:

- Wipe the raceways of any dirt and debris.
- If necessary, remove existing wipers and insert the sliders into the rails. Slightly loosen the fixing screw of the center roller pin.
- Position the slider(s) at the ends of the rail.
- For the U rails there must be a thin support (e.g. set key) under the ends of the slider body to ensure the horizontal alignment of the slider in the flat raceways.
- The included special flat key is inserted from the side between the rail and the slider and inserted onto the hexagonal or square shaft of the eccentric pin to be adjusted (see fig. 25).

Size	Tightening torque [Nm]
20	3
30	7
45	12

Tab. 19

- By turning the flat key clockwise, the eccentric roller is pressed against the upper raceway, thereby removing clearance and setting the correct preload. During this process, absence of play is desired; avoid setting a preload that is so high that it generates high friction and reduces service life.
- Hold the roller with the adjustment key in the desired position and carefully tighten the fixing screw. The exact tightening torque will be checked later.
- Move the slider in the rail and check the preload over the entire length of the rail. It should move easily and the slider should not have play at any location of the rail.
- Tighten the fixing screw with the specified tightening torque (see tab. 19), while holding the flat key and maintaining the angle position of the roller so as to not change the preload while tightening the screw. It is recommended to use thread locking compound.
- Now re-attach the existing wipers if desired.

## > Use of radial ball bearing rollers

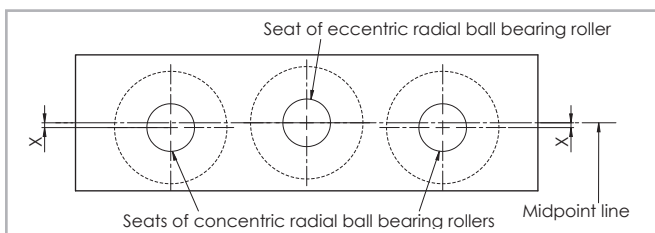

Fig. 26

Slider size	X [mm]
20	0,60
30	0,65
45	0,60

Tab. 20

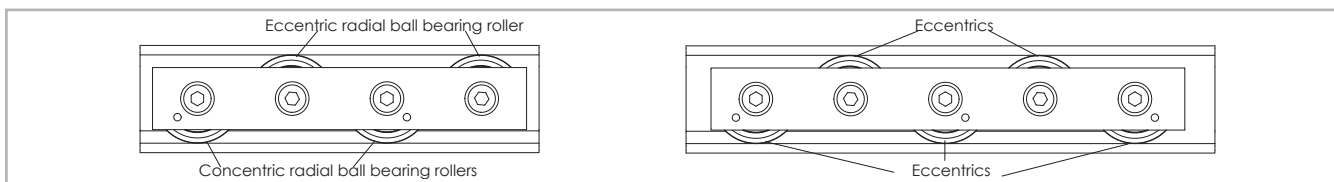

Fig. 27

If purchasing "Radial ball bearing rollers" to install on your own structure (see from p. XR-10 to XR-12) we advise:

- Using a maximum of 2 concentric radial ball bearing rollers

- Offset the seats of the concentric radial ball bearing rollers with respect to those of the eccentric radial ball bearing rollers according to the table (tab. 20).

# Ordering key



## > Rail / slider system

TEX-	960	/1/	CEX20-60	-2RS	
				Roller seal	see pg. XR-4 Performance characteristics
				Slider type	see pg. XR-7, tab. 5 and 6/ pg. XR-9, tab. 9
				Number of sliders in one rail	
				Rail length in mm	see pg. XR-6, tab. 4 / pg.XR-8, tab. 8
				Rail type	see pg. XR-6, tab. 3 / pg. XR-8, tab. 7

Ordering example: TEX-00960/1/CEX20-060-2RS

Hole pitch: 40-11 x 80-40

Notes on ordering: The rail length codes are always 5 digits, the slider length codes are always 3 digits; use zeroes as a prefix when lengths are shorter

## > Rail

TEX-	30-	960	
		Rail length in mm	see pg. XR-6, tab. 4 / pg. XR-8, tab. 8
		Size	see pg. XR-6, tab. 3 / pg. XR-8, tab. 7
		Rail type	see pg. XR-6, tab. 5 / pg.XR-8, tab. 7

Ordering example: TEX-30-00960

Hole pattern: 40-11 x 80-40

Notes on ordering: The rail length codes are always 5 digits; use zeroes as a prefix when lengths are shorter

## > Slider

CES30-80	-2Z	
	Roller seal	see pg. XR-6 Performance characteristics
	Slider type	see pg. XR-7, tab. 5 and 6/ pg. XR-9, tab. 9

Ordering example: CES30-080-2Z

Notes on ordering: The slider length codes are always 3 digits; use zeroes as a prefix when lengths are shorter



## > Accessories

### Roller pins

<b>CRPAX</b>	<b>45</b>	<b>-2RS</b>	
		Roller seal	<i>see pg. XR-6 Performance characteristics</i>
	Size	<i>see pg. XR-11, tab. 13-15</i>	
Roller type	<i>see pg. XR-11, tab. 13-15</i>		

Ordering example: CRPAX45-2RS

### Fixing screws

Rail type	Size	Ordering description
TEX / UEX	20	TORX®-screw TC 18 M4x8 NIC
	30	TORX®-screw TC 28 M5x10 NIC
	45	TORX®-screw TC 43 M8x16 NIC
TES / UES	20	TORX®-screw TC 18 M4x8
	30	TORX®-screw TC 28 M5x10
	45	TORX®-screw TC 43 M8x16

*see pg. XR-12, fig. 20, tab. 16*

